

INDUCTION HEATING AND HARDENING

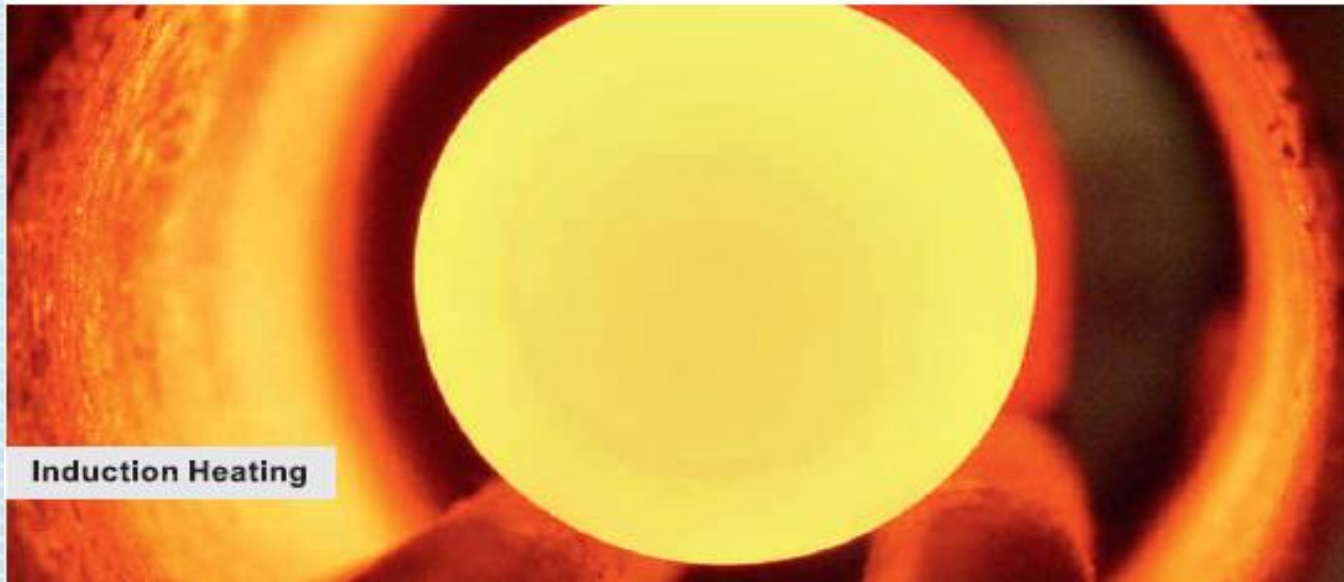

Presentation by:

NITIN JAIN (IHH - SALES & MARKETING)

ELECTROTHERM (INDIA) LTD. - Engineering & Projects Division

72, Palodia, Via Thaltej, Ahmedabad 382 115, Gujarat, INDIA

Office : +91 2717 660 550 | Website : www.electrothermenp.com

Mob.: +91-7046088877 | Email: nitin.sjain@electrotherm.com

BASIC PRINCIPLES OF INDUCTION

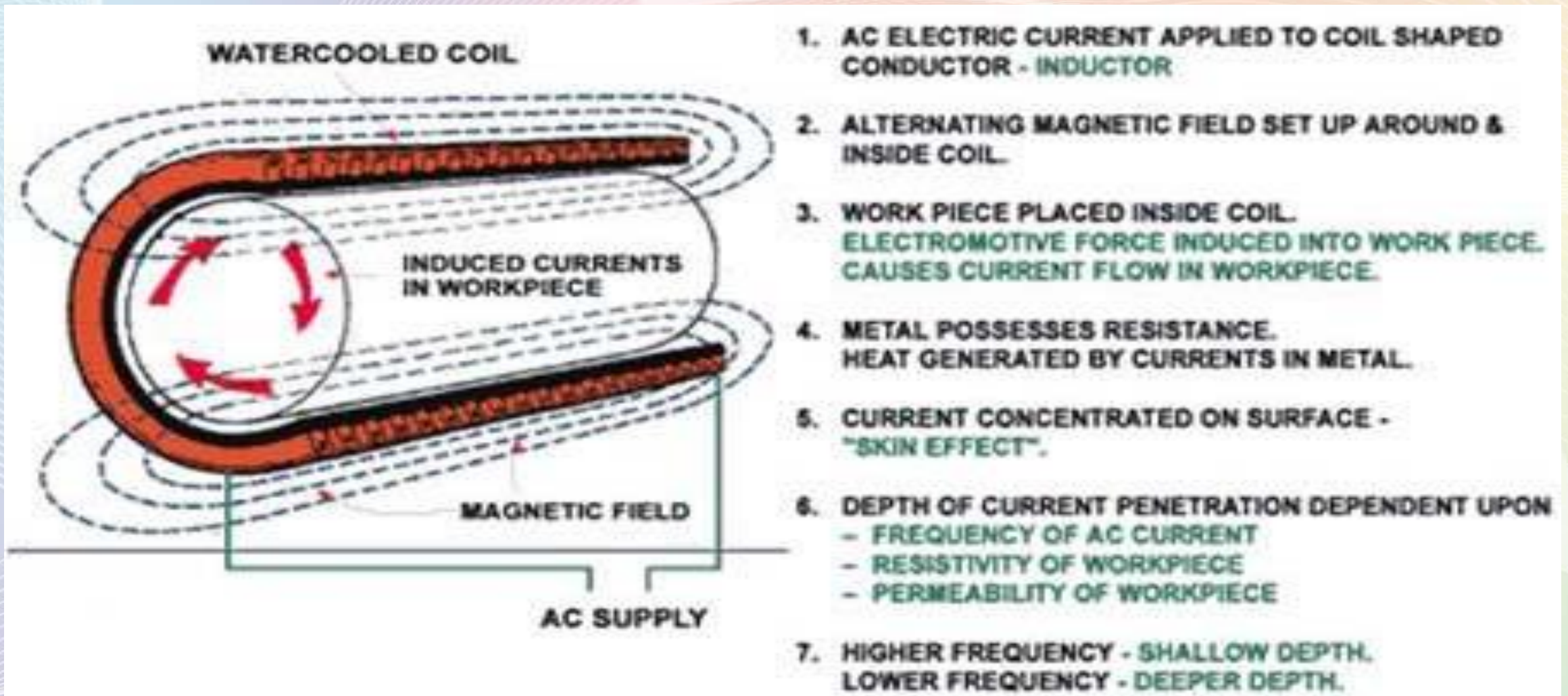

1. AC ELECTRIC CURRENT APPLIED TO COIL SHAPED CONDUCTOR - INDUCTOR
2. ALTERNATING MAGNETIC FIELD SET UP AROUND & INSIDE COIL.
3. WORK PIECE PLACED INSIDE COIL. ELECTROMOTIVE FORCE INDUCED INTO WORK PIECE. CAUSES CURRENT FLOW IN WORKPIECE.
4. METAL POSSESSES RESISTANCE. HEAT GENERATED BY CURRENTS IN METAL.
5. CURRENT CONCENTRATED ON SURFACE - "SKIN EFFECT".
6. DEPTH OF CURRENT PENETRATION DEPENDENT UPON
 - FREQUENCY OF AC CURRENT
 - RESISTIVITY OF WORKPIECE
 - PERMEABILITY OF WORKPIECE
7. HIGHER FREQUENCY - SHALLOW DEPTH. LOWER FREQUENCY - DEEPER DEPTH.

ADVANTAGES OF INDUCTION HEATER

- Rapid Startup
- Uniform Temperature Profile (of Surface to Core and Head to tail)
- Pollution Free System (Environmentally Acceptable)
- Reduced Scale and Scale loss
- Increased Die Life
- Lowest Specific Energy consumption
- Highest Power Factor (>0.98)
- Higher productivity per KVA (Kg/Hr. per KVA) and Efficiency
- Automatic Handling
- Quality Control

INDUCTION EQUIPMENTS FOR VARIOUS APPLICATION



TYPICAL APPLICATIONS

- Billet Heating Ferrous and Non Ferrous
- Extrusion
- Piercing
- Long Bar Heating
- End Bar Heating
- In-Line Billet Heating
- Aluminum Cast Bar Heating
- Flat and Plate Heating
- Rebar Coating

TYPICAL APPLICATIONS

- Pipe Heating / Pipe End Heating / Pipe Bending / Pipe Annealing / Pipe Coating / Pipe Quench & Tempering
- Heat Treatments like Case Hardening, Tempering, Annealing, Stress Relieving
- Pipe Seam Annealing / Rock Bit Annealing
- Tube and Wire Heating
- Cookware Bottom Brazing / Pump Rotor Brazing
- Shrink Fitting
- Cap Sealing
- Strip Dryer

EQUIPMENTS FOR FORGING & EXTRUSION INDUSTRIES

- Induction Billet Heater for Ferrous and Non Ferrous
- Induction Long Bar Heater
- Induction End Bar Heater

INDUCTION BILLET HEATER

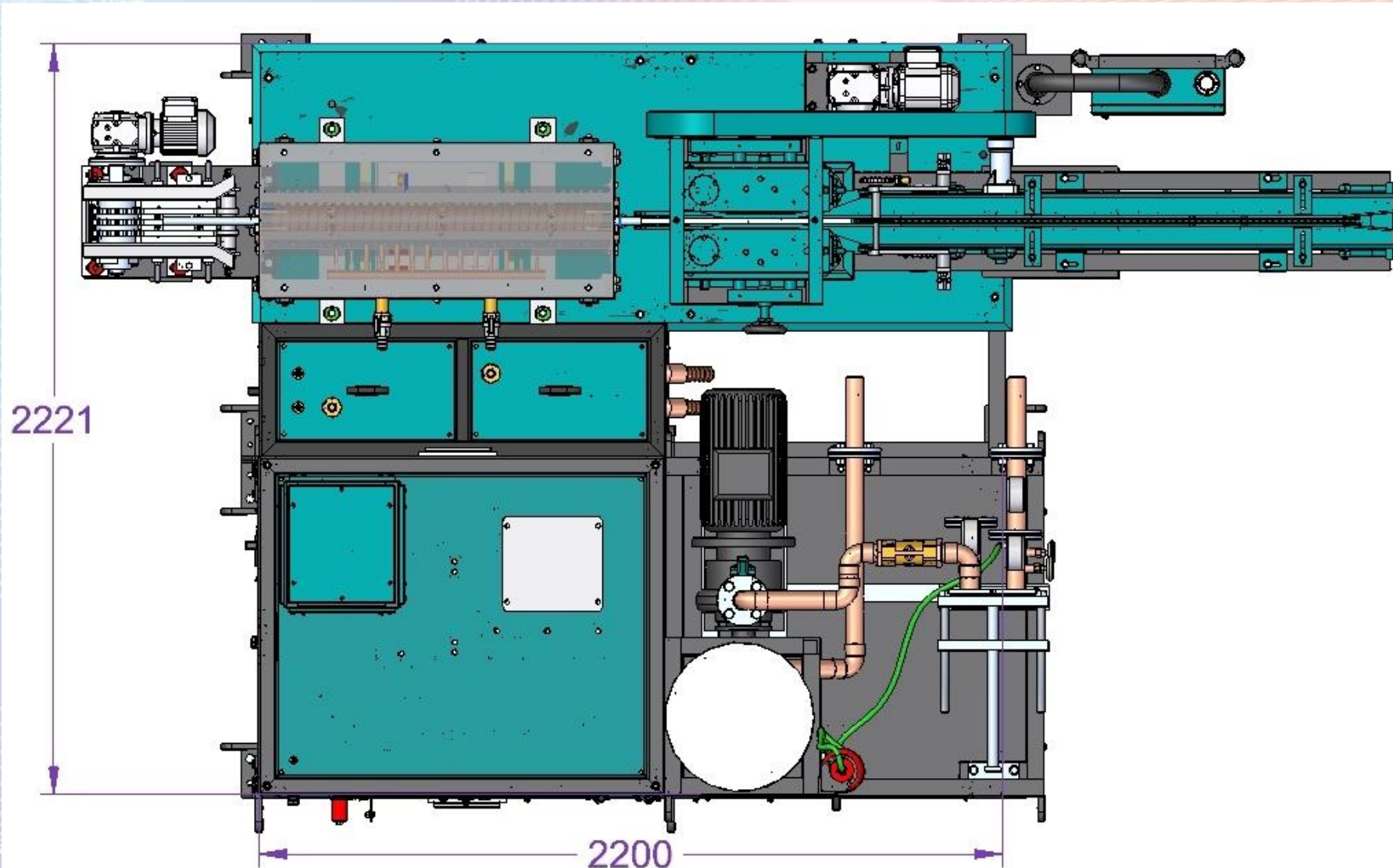

- Induction Heating System with rating : Up to 250 KW
- Floor Space : 2.2 Meter x 2.2 Meter

INDUCTION HEATER COIL ASSEMBLY

- EC Grade copper winding with required thickness of Rectangular section
- Refractory casted
- DM water used as cooling
- S.S Billet Guide skid/rail with Stellite Rod
- Main Outlet with RTD, each outlet path with Temperature sensor
- Quick Power & water connection

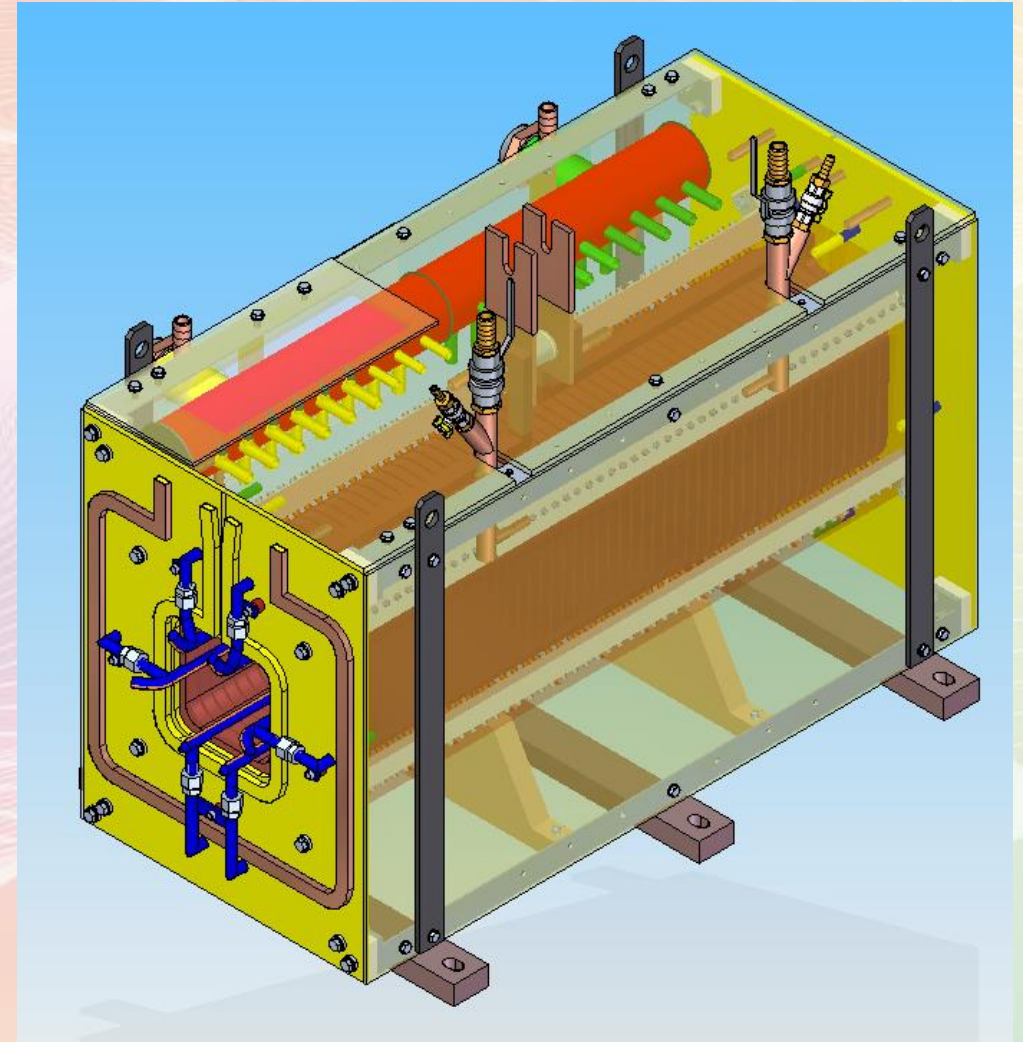

INDUCTION BILLET HEATER – MODEL I



INDUCTION BILLET HEATER – MODEL I



INDUCTION BILLET HEATER – MODEL I

IGBT ASSEMBLY WITH DRIVER CARDS



SINGLE DIGITAL CONTROLLER CARD



INDUCTION BILLET HEATER HMI SCREEN

DIGITAL DISPLAY ON COLOR HMI FOR JOB RECIPE LIKE
JOB TYPE, DIA./RCS, LENGTH, CYCLE TIME, KG/HR.

2:20 (PM) **PRDUCTION PARAMETER** 9/ 8/16

JOB SELECTION	RCS
JOB DIA / HEIGHT	65
JOB LENGTH (MM)	255
NO OF JOBS/MIN	1.71
PRODUCTION RATE (KG/HR)	874

MAIN

BILLET FEEDING DEVICES

STEPPER CONVEYOR



HYDRAULIC PUSHER



INFEEED CONVEYOR

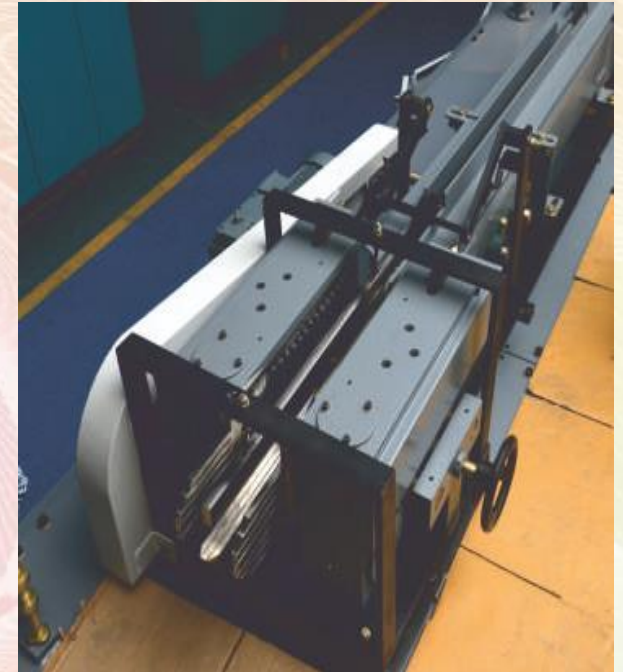

PNEUMATIC PUSHER



BILLET EXTRACTION DEVICES

QUICK EXTRACTOR

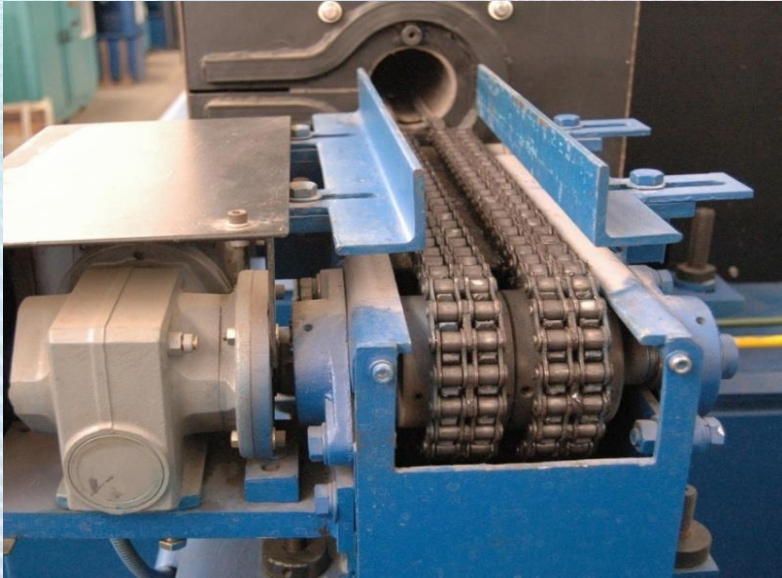

ACCEPT / REJECT SYSTEM

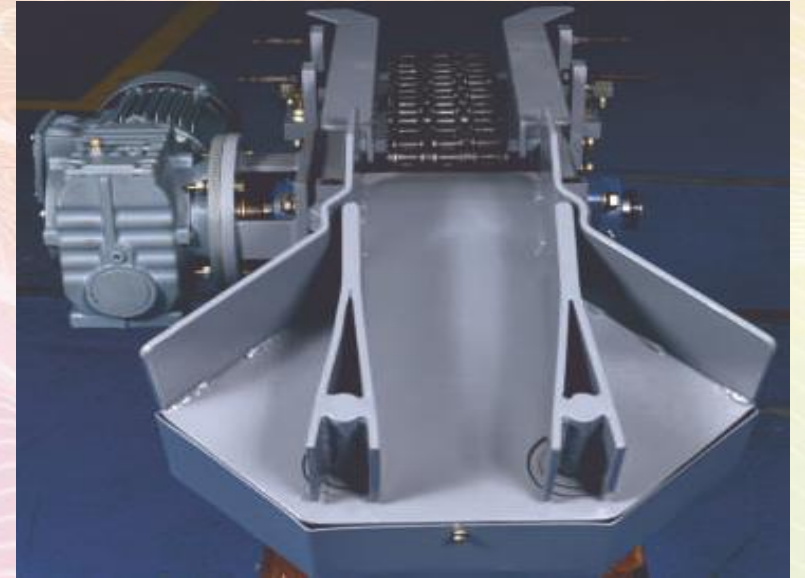

GRABBER SYSTEM

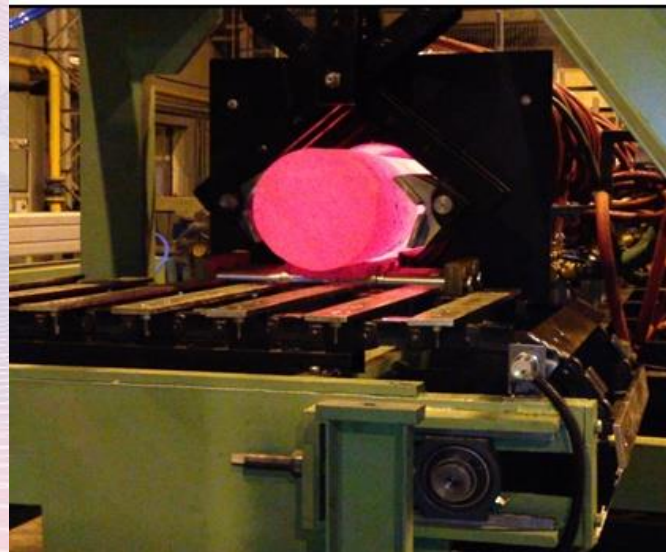

INDUCTION BILLET HEATER – MODEL II

- LOW-BOY : Induction Heating System
- Rating : 300 KW to 1000 KW
- Structure : PSU + COIL + Mechanics In-feed / Pneumatic / Hydraulic Pusher / Bin Tipper / Stepper Conveyor / Fast Extractor / Accept-Reject Mechanism

INDUCTION BILLET HEATER – MODEL II (VIDEO)



INDUCTION BILLET HEATER – MODEL II

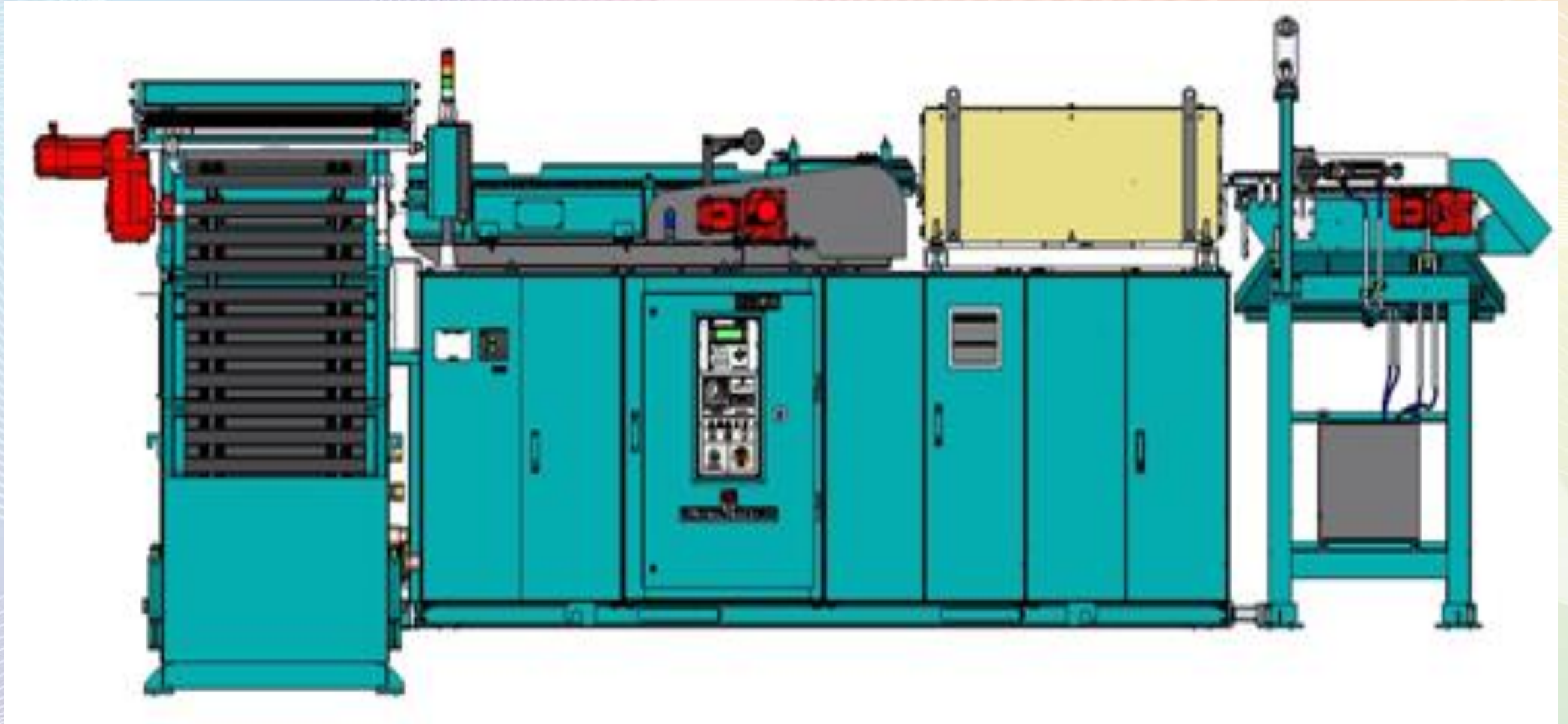

INDUCTION BILLET HEATER – MODEL II

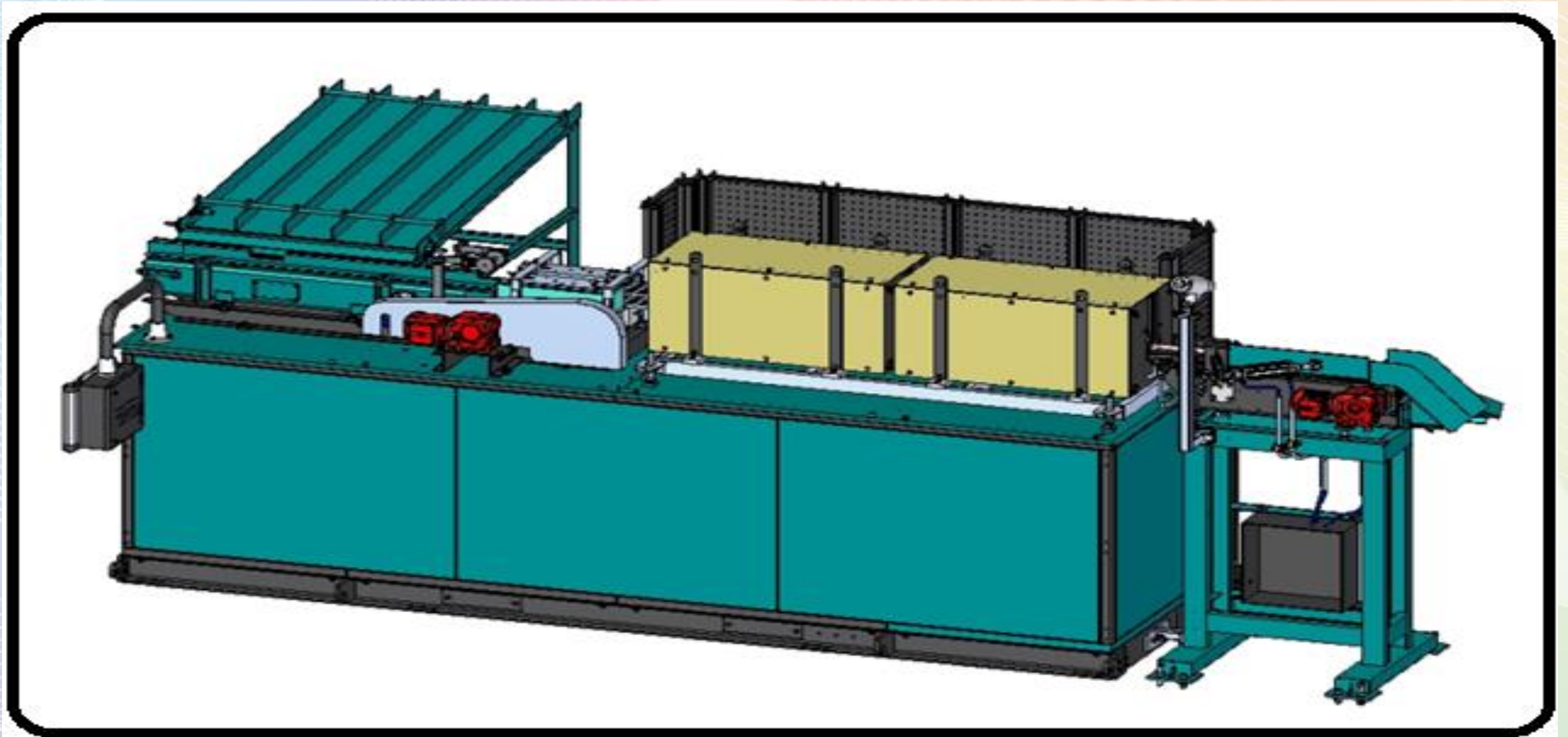

BRASS INDUCTION BILLET HEATER (VIDEO)

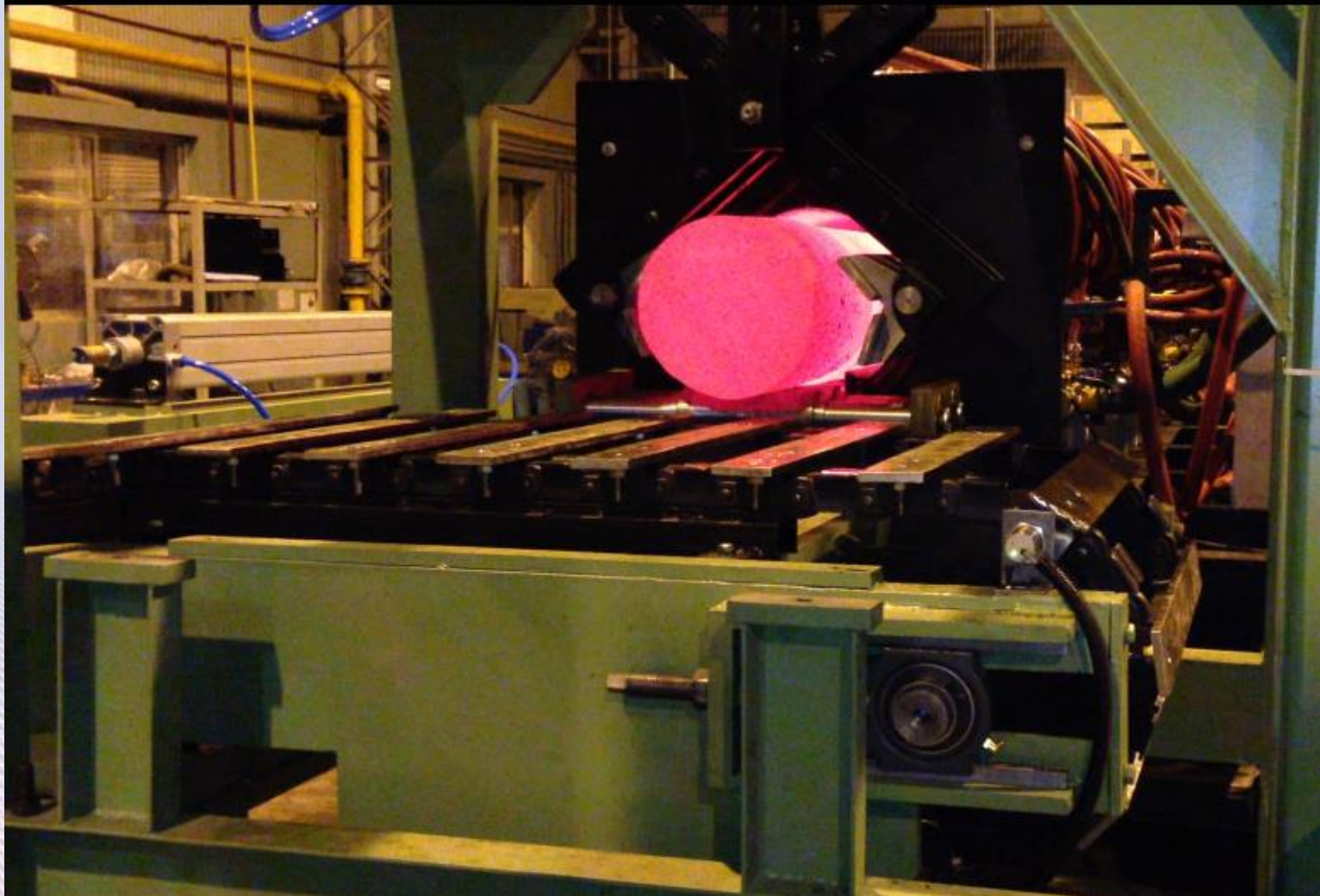

MODULAR INDUCTION BILLET HEATER – MODEL III

- Modular Concept: Induction Heating System
- Rating : 1000 KW to 4000 KW
- Structure : PSU + COIL + Mechanics In-feed / Hydraulic Pusher / Bin Tipper/ Stepper Conveyor / Fast Extractor/ Accept-Reject Mechanism

MODULAR INDUCTION BILLET HEATER – MODEL III



INDUCTION LONG BAR HEATER

Used for Forging applications to manufacture products like:

- Hand Tools
- Bearing & Bearing races
- Shafts
- Flanges
- Automotive Components
- Couplings etc.

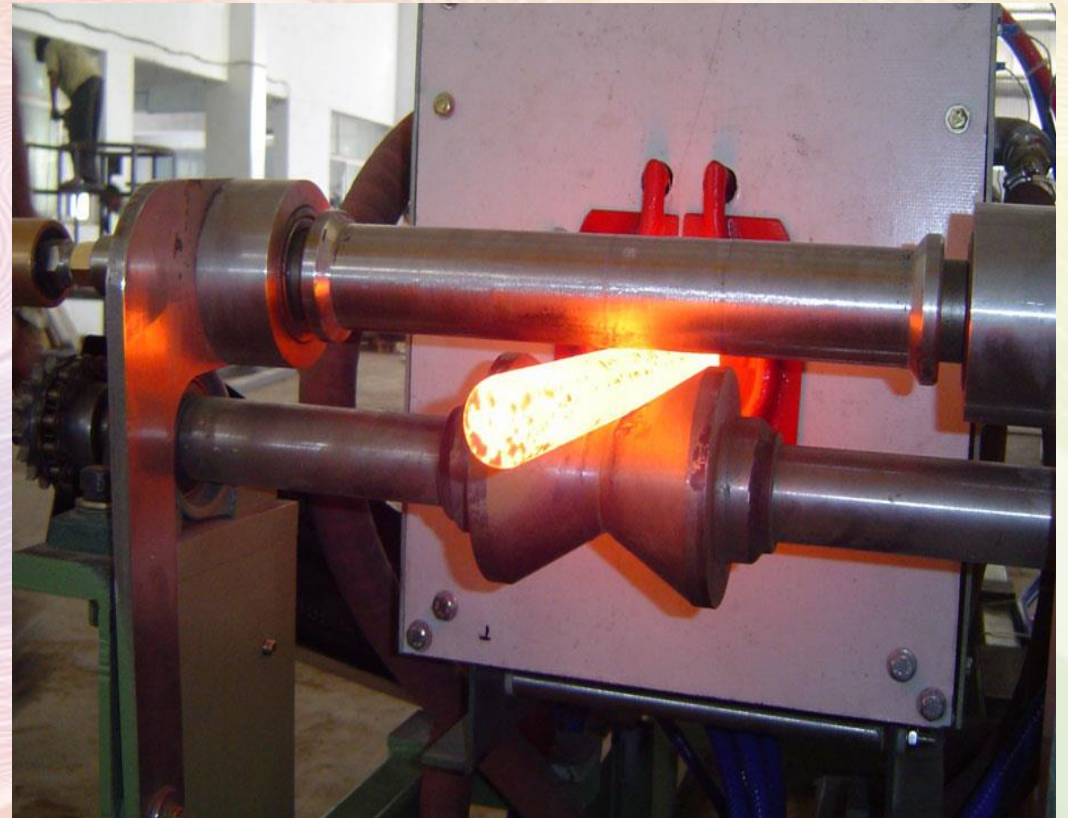

INDUCTION LONG BAR HEATER



Power rating: 50 kW to 4000 kW

Frequency: 300 Hz to 30 KHz

Bar Size: Dia. 16 mm to 200 mm

HEAVY DUTY ROLLER ASSEMBLY

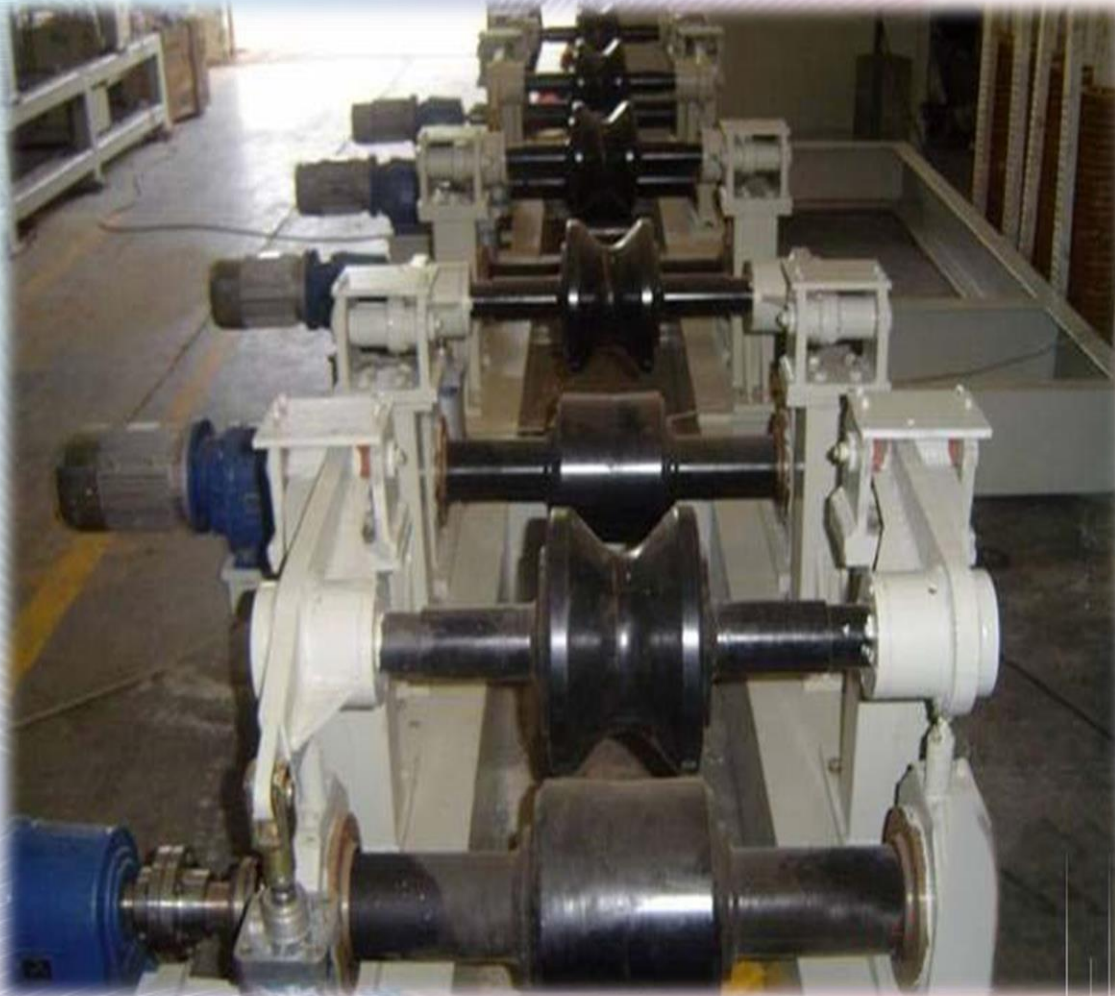

PINCH ROLLER ASSEMBLY



INDUCTION END BAR HEATER

Forging process where End/Center portion of jobs are heated to manufacture:

- Axles & Shafts
- U Bolt
- Valves
- Couplings
- Gas Cylinders
- Files
- Hand Tools
- With Upset Forging Machines

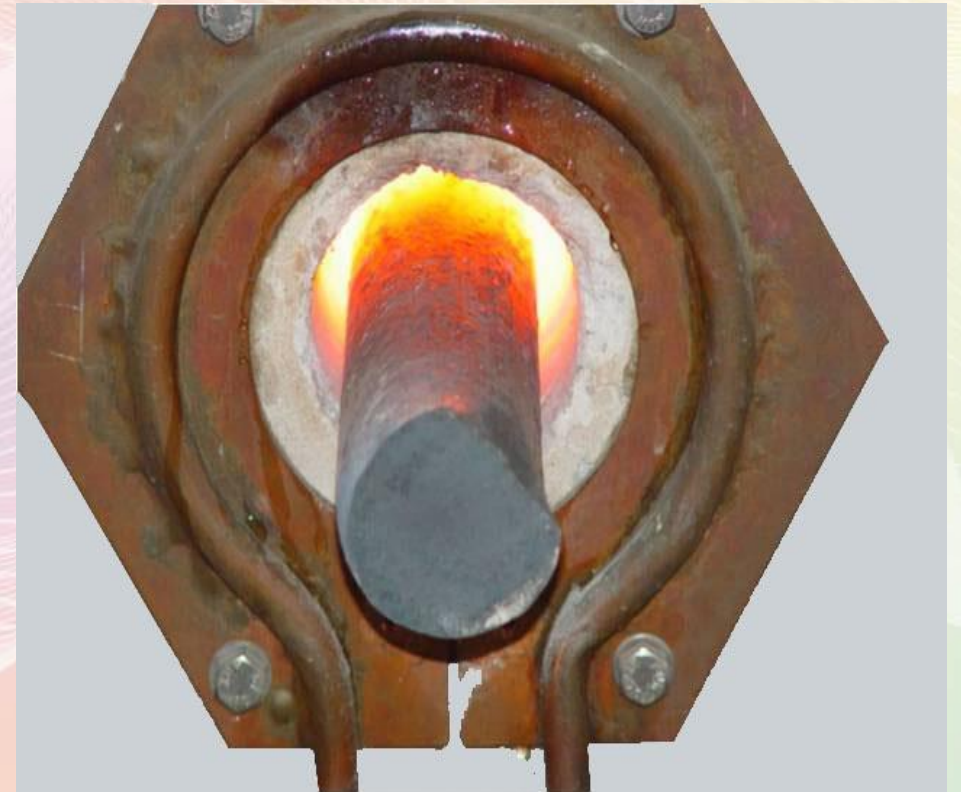

COIL MOVING TYPE END BAR HEATER



Power rating: 50 kW to 4000 kW

Frequency: 300 Hz to 30 KHz

Bar Size: Dia. 16 mm to 120 mm

CONVENTIONAL TYPE END BAR HEATER



INDUCTION HARDENING SYSTEM

**H
E
A
T
I
N
G**



**Q
U
A
L
I
T
Y
-
I
N
T
E
R
N
A
T
I
O
N
A
L**

INDUCTION HARDENING SYSTEM

- ◆ Inductor
- ◆ Quench Barrel
- ◆ Part
- ◆ Locator



APPLICATIONS OF INDUCTION HARDENING SYSTEM

Crank Shaft, Cam Shaft, Axles as well as other automobile and railway components

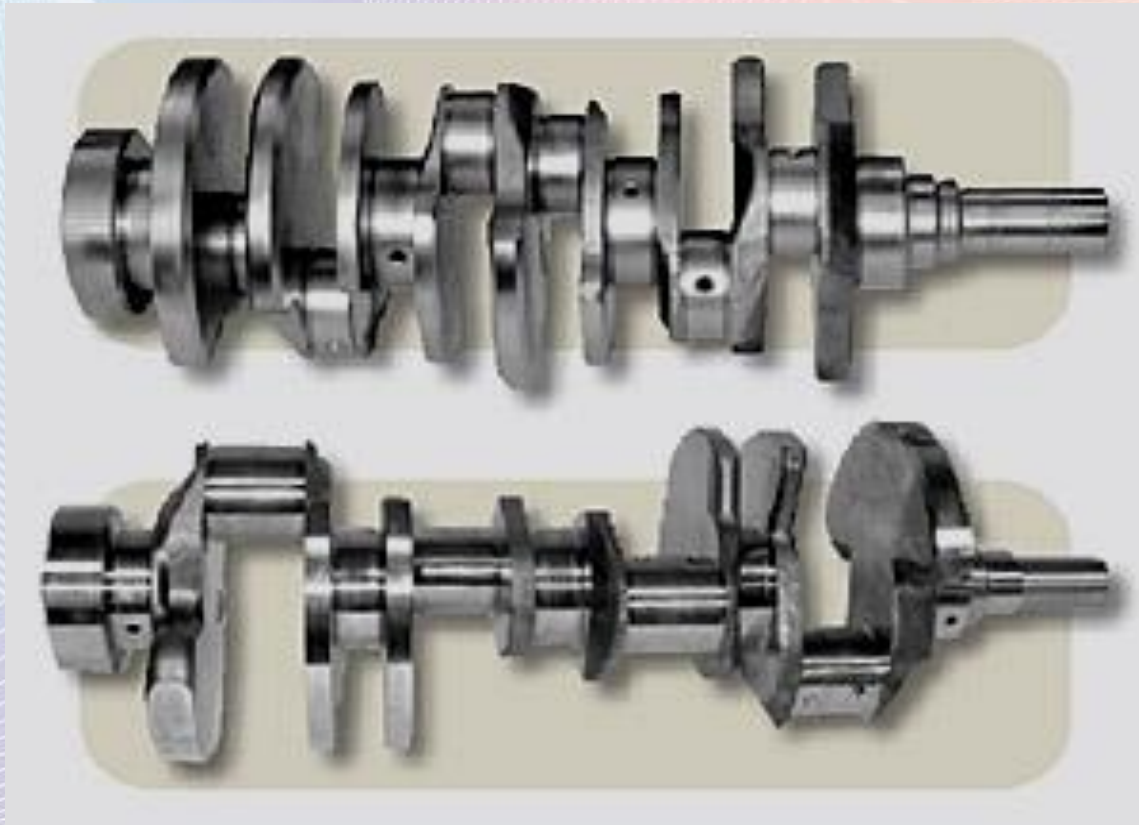

INDUCTION SHAFT HARDENING



INDUCTION HARDENING SCANNER



INDUCTION HARDENING SCANNER

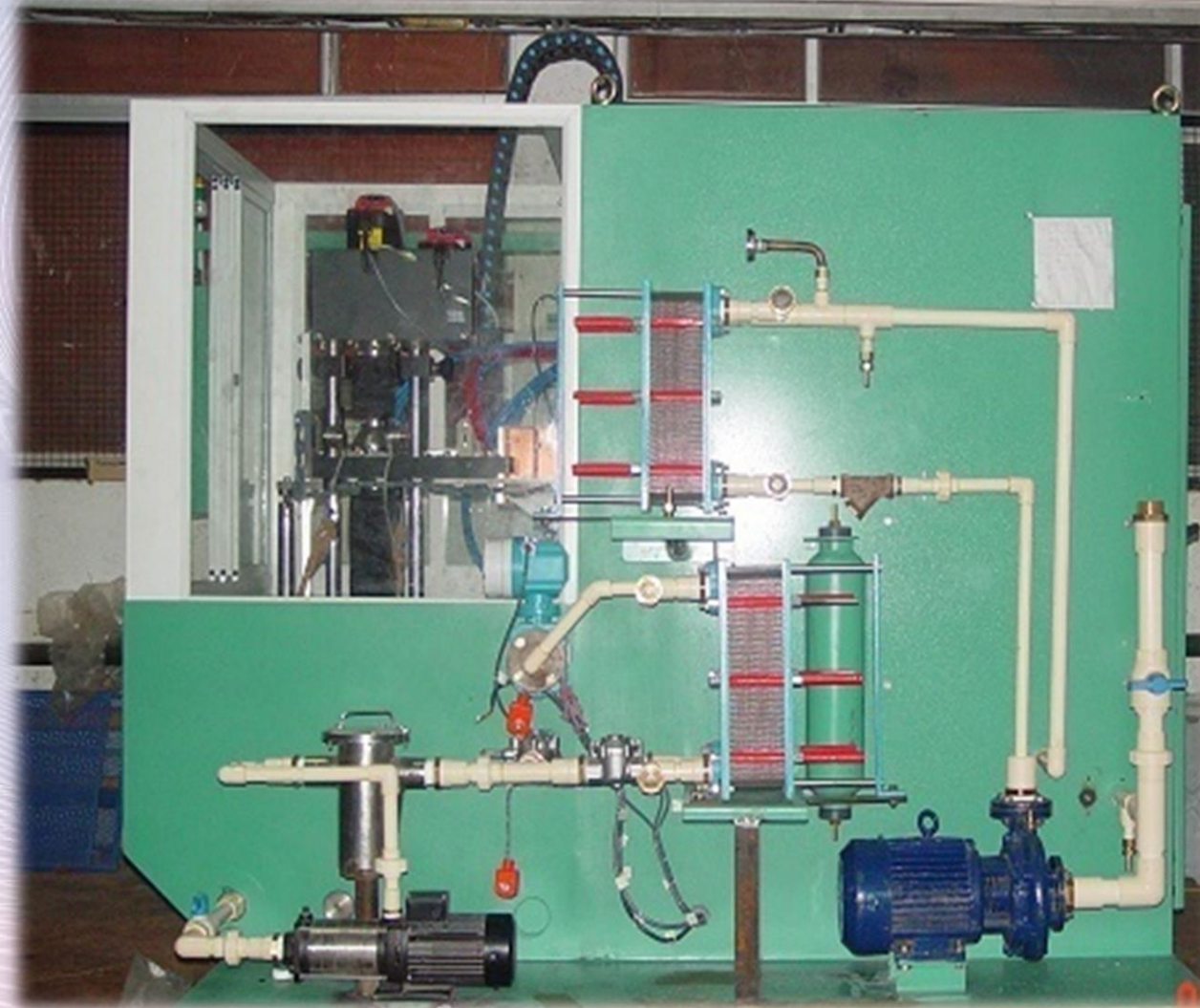

INDUCTION HARDENING LARGEST SCANNER



3 METERS SCANNING LENGTH

**200 kW / 10 kHz Vertical Scanner for
Hydraulic Cylinder Piston hardening
Job Dia. from 50 mm to 300 mm**

1200 mm SCANNER WITH UNITISED CONCEPT



VERTICAL DUAL SPINDLE SCANNER



CNC CONTROL UNIT FOR HARDENING MACHINE



EXTENSIVE DOMESTIC REACH

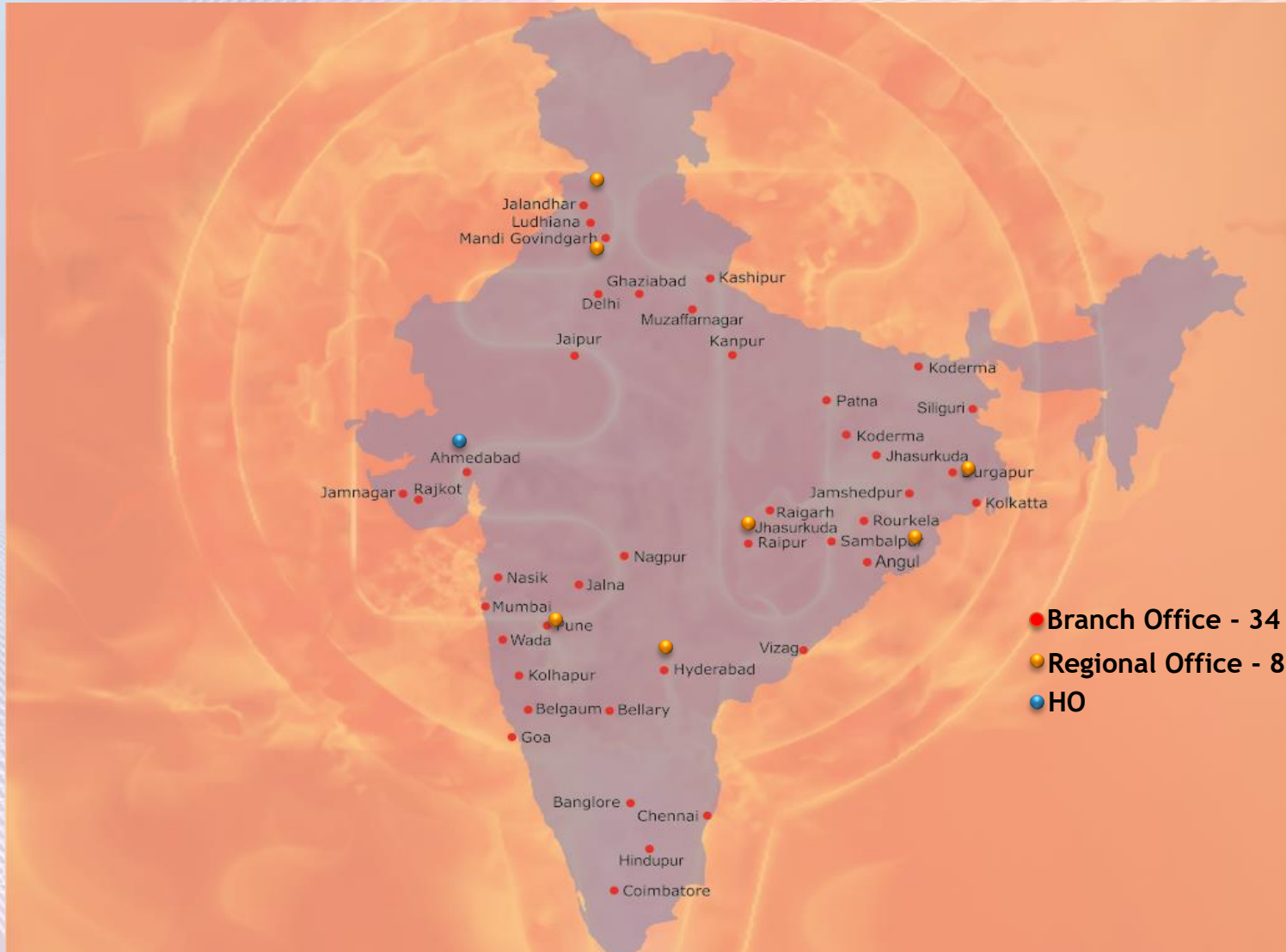

EXTENSIVE GLOBAL REACH



Thank You !!